

DS-15HT

Two-way Loudspeaker System

The DS-15HT is a compact, coaxial-driver, 2-way, highly weather-resistant full range loudspeaker with high SPL, the body is made of engineering plastic injection molding, equipped with or without multi-tap transformers, conforms to IP65 international standard.



Features:

- Product parameters have been entered into EASE loudspeaker database
- Pass IP65 testing, meet all-weather use
- The cabinet is made of polymer compound injection molding
- Coaxial point sound source
- Horn-loaded design
- Applications: parks, plazas, stadiums, sound reinforcement of scenic areas, transportation hubs, seascides(customized)

Overall dimensions

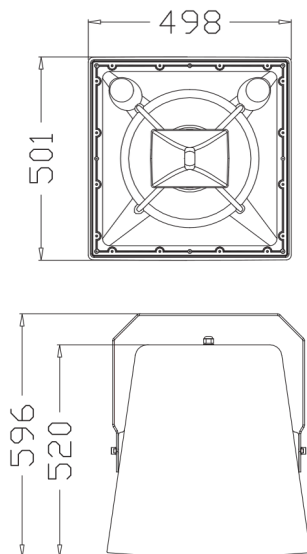

Technical specifications

FREQUENCY RESPONSE (-3dB)	50Hz-18kHz
DRIVERS	1×15" (385mm)/3" voice coil LF
	1×1.4" (36mm) /3"voice coil HF
INPUT VOLTAGE	100V
POWER	75W/150W/300W/OFF/8Ω 500W
SENSITIVITY	103 dB 1 watt/1 metre
MAXIMUM SPL	129 dB continuous, 135dB peak
IMPEDANCE	8 ohms nominal
DISPERSION(-6 dB)	60°×40°
CROSSOVER	1.5 kHz passive
DIMENSIONS	(W)498mm×(H)501mm×(D)596mm
WEIGHT	31kg/pc

