

EN54-24 Horn Speaker DS-EN60HS

Feature:

- Compliant with the EN54-24 standards
- Public Address (PA) system paging horn speaker
- Outdoor horn loudspeaker with 100V/70V transformer
- Ideal for outdoor paging and speech use in school, office, hotel and airport
- Superior long distance voice speech clear & crystal delivery
- Multiple power taps of 30-15-10W & 8 Ohm
- Waterproof level of IP66
- Line input 100V or 70V by speaker cable tail
- Ceramic connector, 95°C fire-resistant cable and thermal fuse
- ABS UV fire-resistant enclosure and stainless metal bracket in white
- Quick installation by supplied stainless mounting bracket



EN54-24

Specification:

Model	DS-EN60HS
Description	EN54-24 Horn Speaker
Power Taps	30-15-10W & 8 Ohm
Line Input	100V or 70V
Frequency Response	300-8KHz
SPL(@1W/m)	110dB
IP Rate	IP66
Dimension	290×213×293mm
Net Weight	2kg
Material	ABS UV fire-resistant enclosure and stainless metal bracket in white
Mounting Way	Quick installation by supplied stainless mounting bracket

Side View & Dimension:

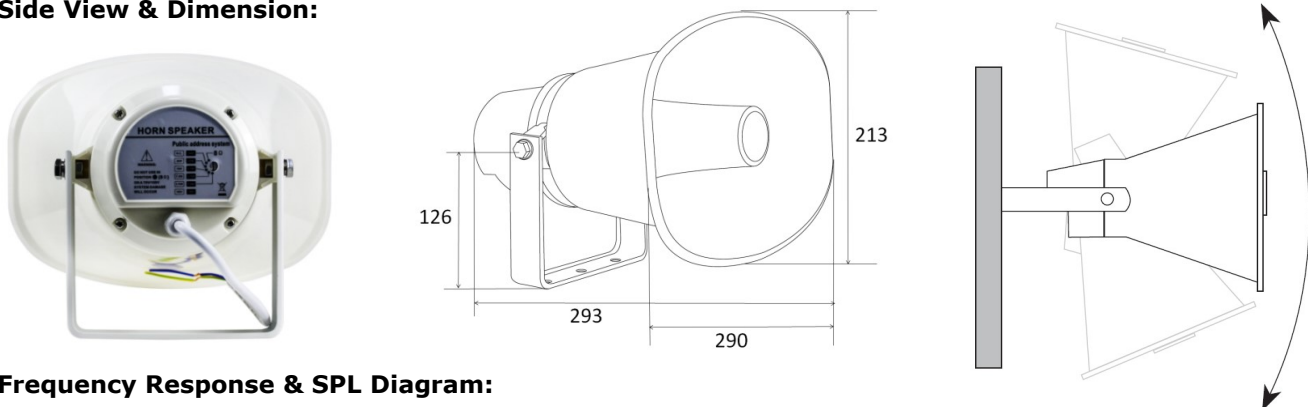

Frequency Response & SPL Diagram:

